



## Modular Cooking Range Line 700XP Full Module Gas Grill Top - Town Gas

ITEM # \_\_\_\_\_

MODEL # \_\_\_\_\_

NAME # \_\_\_\_\_

SIS # \_\_\_\_\_

AIA # \_\_\_\_\_



371244 (E7GRTHGC0P)

Full module gas PowerGrill  
Top - HP - town gas

### Short Form Specification

Item No. \_\_\_\_\_

To be installed on open base installations, bridging supports or cantilever systems. High efficiency 14 kW stainless steel gas burners with flame failure device, optimized combustion and protected pilot light. Suitable for town gas. Cooking surface grids in enameled cast iron, easily removable for cleaning. Exterior panels in stainless steel with Scotch Brite finish. One piece pressed work top in 1.5 mm thick stainless steel. Right-angled side edges to allow flush-fitting junction between units.

### Main Features

- Unit to be mounted on open base cupboards, bridging supports or cantilever systems.
- Stainless steel burners with flame failure device, optimized combustion and protected pilot light.
- AISI 441 stainless steel deflective shields located below the radiants prevent burners from clogging, minimize flare ups and ensure even heat distribution (PATENT US9591947B2 and related family).
- Dishwasher-safe radiants removable without the use of tools to facilitate cleaning.
- Stainless steel high splash guards on the rear and sides of cooking surface. Splash guards can be easily removed for cleaning and are dishwasher-safe.
- Cooking grids made in highly resistant enameled cast iron for easy cleaning.
- Suitable for countertop installation.

### Construction

- All exterior panels in Stainless Steel with Scotch Brite finishing.
- One piece pressed 1.5 mm work top in Stainless steel.
- Model has right-angled side edges to allow flush fitting joints between units, eliminating gaps and possible dirt traps.
- IPx4 water protection.

APPROVAL: \_\_\_\_\_



Experience the Excellence  
[www.electroluxprofessional.com](http://www.electroluxprofessional.com)

**Optional Accessories**

- |  |            |                          |
|--|------------|--------------------------|
| • Junction sealing kit                               | PNC 206086 | <input type="checkbox"/> |
| • Support for bridge type installation, 800mm        | PNC 206137 | <input type="checkbox"/> |
| • Support for bridge type installation, 1000mm       | PNC 206138 | <input type="checkbox"/> |
| • Support for bridge type installation, 1200mm       | PNC 206139 | <input type="checkbox"/> |
| • Support for bridge type installation, 1600mm       | PNC 206141 | <input type="checkbox"/> |
| • Right and left side handrails                      | PNC 206307 | <input type="checkbox"/> |
| • Back handrail 800 mm                               | PNC 206308 | <input type="checkbox"/> |
| • Scraper kit with hooks for HP grills               | PNC 206347 | <input type="checkbox"/> |
| • Base support for feet or wheels - 1600mm (700/900) | PNC 206369 | <input type="checkbox"/> |
| • Frontal handrail, 800mm                            | PNC 216047 | <input type="checkbox"/> |
| • Frontal handrail, 1200mm                           | PNC 216049 | <input type="checkbox"/> |
| • Frontal handrail, 1600mm                           | PNC 216050 | <input type="checkbox"/> |
| • Large handrail - portioning shelf, 400mm           | PNC 216185 | <input type="checkbox"/> |
| • 2 side covering panels for top appliances          | PNC 216277 | <input type="checkbox"/> |

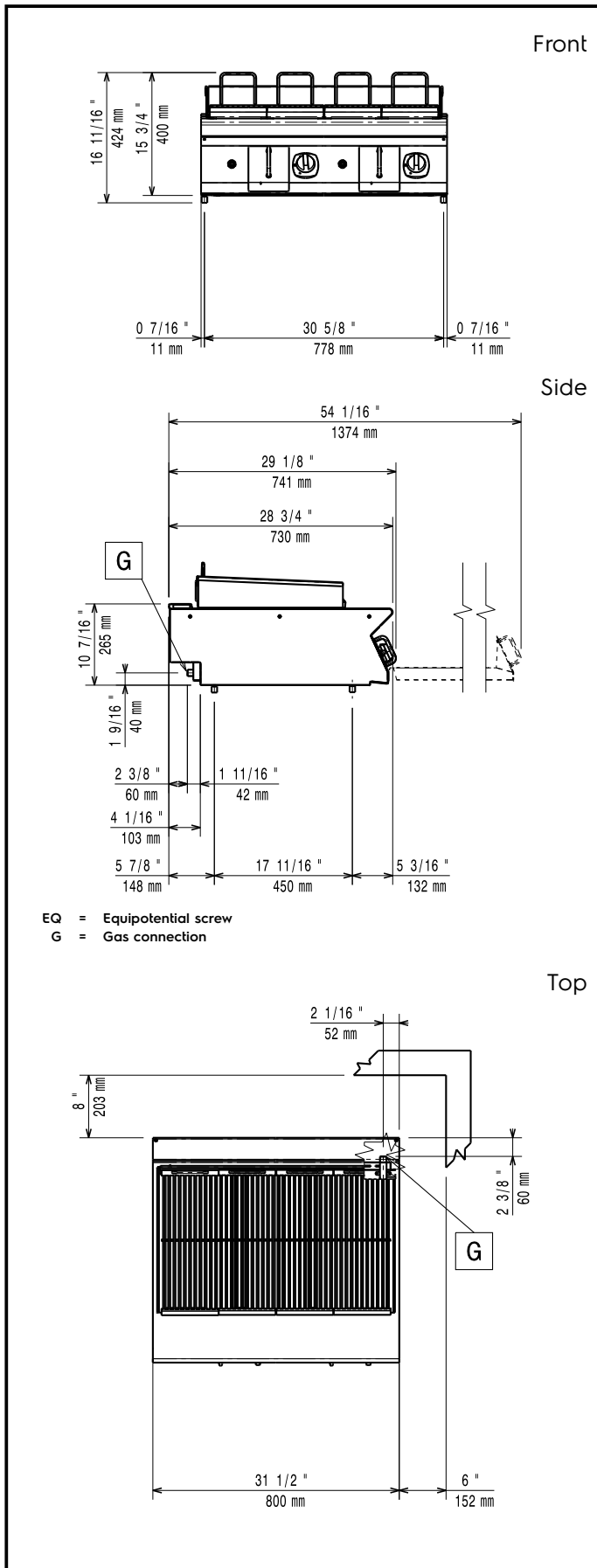

### Gas

Gas Power:	14 kW
Standard gas delivery:	Natural Gas G20 (20mbar)
Gas Type Option:	
Gas Inlet:	1/2"

### Key Information:

If appliance is set up or next to or against temperature sensitive furniture or similar, a safety gap of approximately 150 mm should be maintained or some form of heat insulation fitted.

Net weight:	68 kg
Shipping weight:	80 kg
Shipping height:	540 mm
Shipping width:	850 mm
Shipping depth:	800 mm
Shipping volume:	0.37 m <sup>3</sup>
Certification group:	N7EGG
Cooking surface width:	742 mm
Cooking surface depth:	472 mm